

PROTEGO® UB/SF-IIB3

The unique deflagration-, endurance burning- and frost-proof pressure/vacuum relief valve

It is primarily used as a safety device for flame transmission proof in- and outbreathing on tanks, containers and other process equipment.

PROTEGO® UB/SF-IIB3

- approved for vapours in explosion group IIB3 and for set pressure/vacuum from 3.5 mbarg and greater
- type-approved according to ATEX Directive 94/9/EC and EN ISO 16852
- protection against atmospheric deflagrations and endurance burning



Benefits

- high performance seal reducing product loss below EPA's 500ppm rule preventing environmental pollution
- set pressure close to opening pressure enables optimum pressure maintenance in the system
- liquid column height is monitored by level indicators (see picture on the right)
- freeze protection at sub-zero conditions (see picture 1 on the back)
- hinged design – maintenance friendly (see picture 2 on the back)
- self draining function for condensate
- particularly suitable for problematic products such as monomers, polymerizing media and vapours with a tendency to condensate, etc.

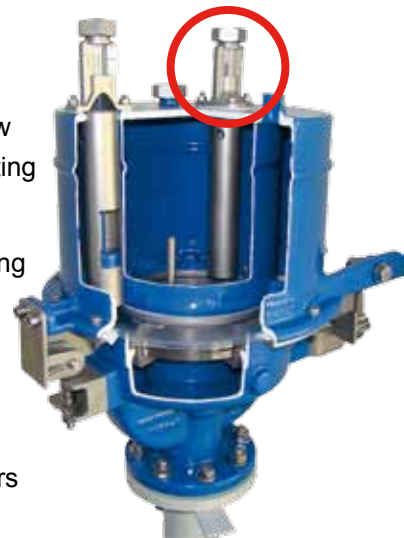

for safety and environment



picture 1: operating safety even at sub-zero conditions



picture 2: excellent accessibility for maintenance work

Operation of UB/SF (Inbreathing)

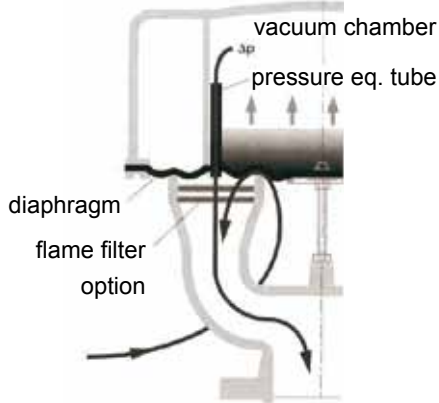

Operation of UB/SF (Outbreathing)

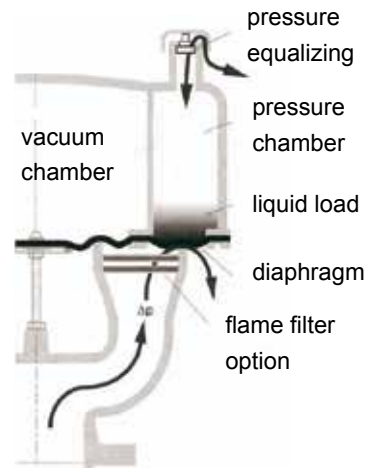

Design of the PROTEGO® UB/SF-IIB3

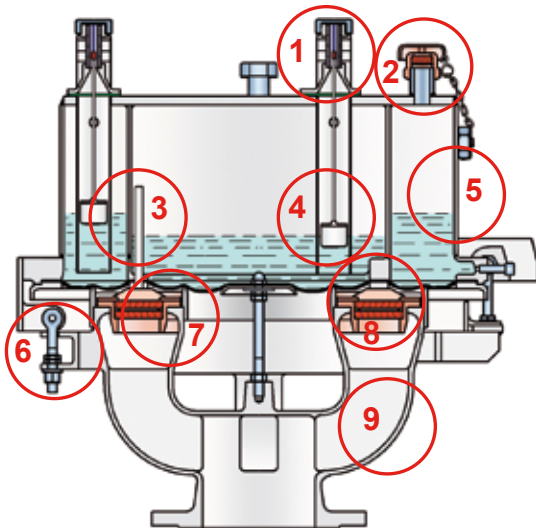

- 1 Liquid level indicator 2 Vent cap
- 3 Pressure compensation pipe 4 Float
- 5 Valve top 6 Locking element 7 Diaphragm
- 8 PROTEGO® flame arrester unit 9 Housing

Feel free to contact us with any questions!
Our PROTEGO® team is happy to consult you!

Braunschweiger Flammenfilter GmbH
Industriestrasse 11
D - 38110 Braunschweig
phone: +49 (0) 5307 / 809-0
fax: +49 (0) 5307 / 78 24
e-mail: office@protego.de

web: www.protego.de



for safety and environment